

YFT SERIES

- ★ 三层高密分子涂漆，
隔绝灰尘更耐高温。
- ★ 高端滚珠轴承，
减少摩擦提升传动效率。
- ★ 优质合金钢精密磨齿，
提高啮合精度保证品质。

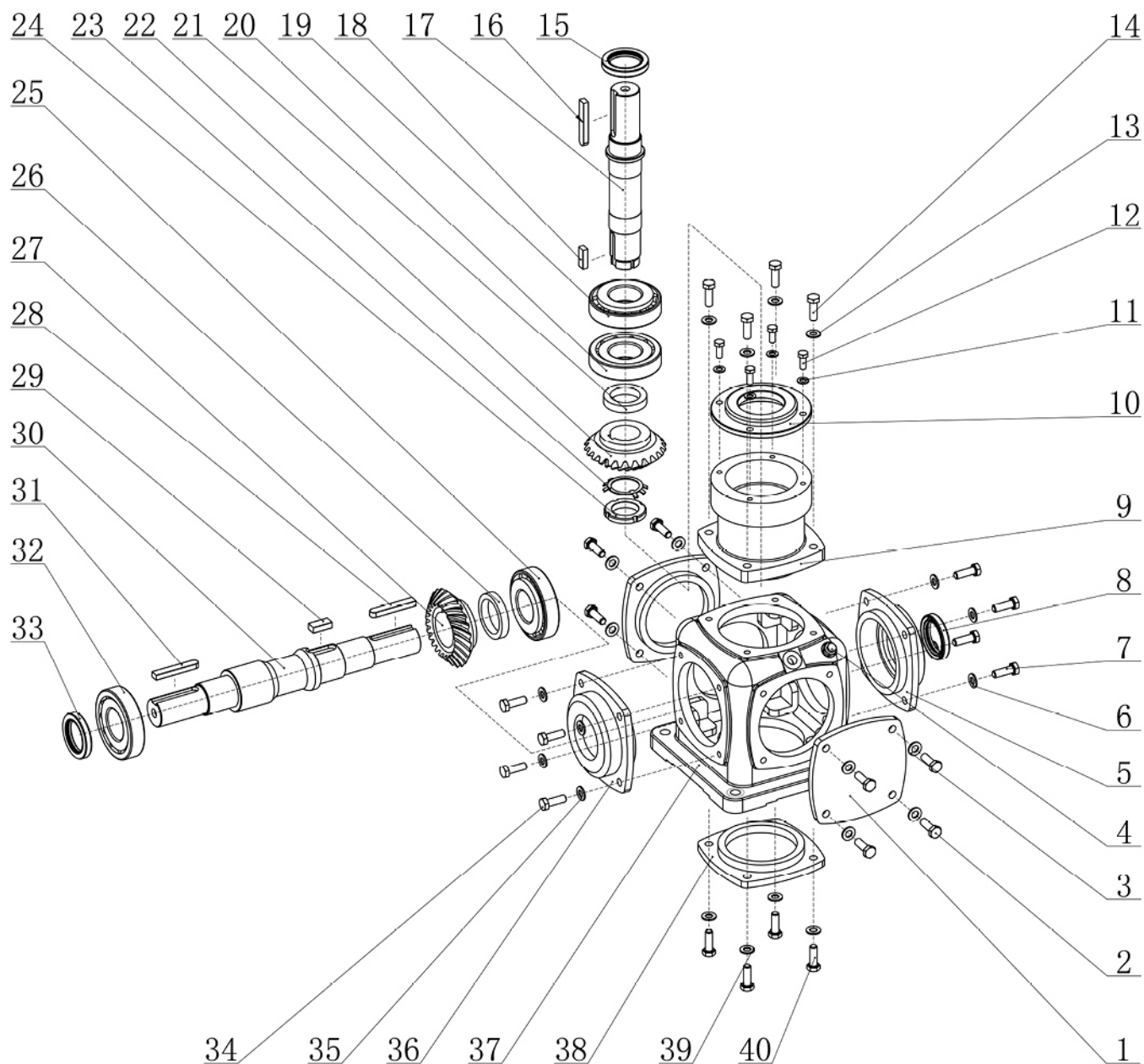

雁峰集团
www.yanfenggroup.cn



T系列爆炸图

1.端盖	11.平垫圈	21.轴套	31.平键
2.螺栓	12.螺栓	22.齿轮	32.轴承
3.平垫圈	13.平垫圈	23.止动环	33.骨架油封
4.透气塞	14.螺栓	24.圆螺母	34.螺栓
5.轴承盖	15.骨架油封	25.轴承	35.平垫圈
6.平垫圈	16.平键	26.轴套	36.轴承盖
7.螺栓	17.轴	27.齿轮	37.箱体
8.骨架油封	18.平键	28.平键	38.端盖
9.轴承座	19.轴承	29.平键	39.平垫圈
10.透盖	20.轴承	30.轴	40.螺栓

YFT系列螺旋锥齿轮转向箱

YFT series Helical-bevel Gearbox

YFT系列螺旋锥齿轮转向箱, 传递动力大, 能适应正反转, 震动小, 噪音低。

YFT series helical-bevel gearbox, large in transmission force, geared to both to both forward and backward rotation, small in vibration and noise.

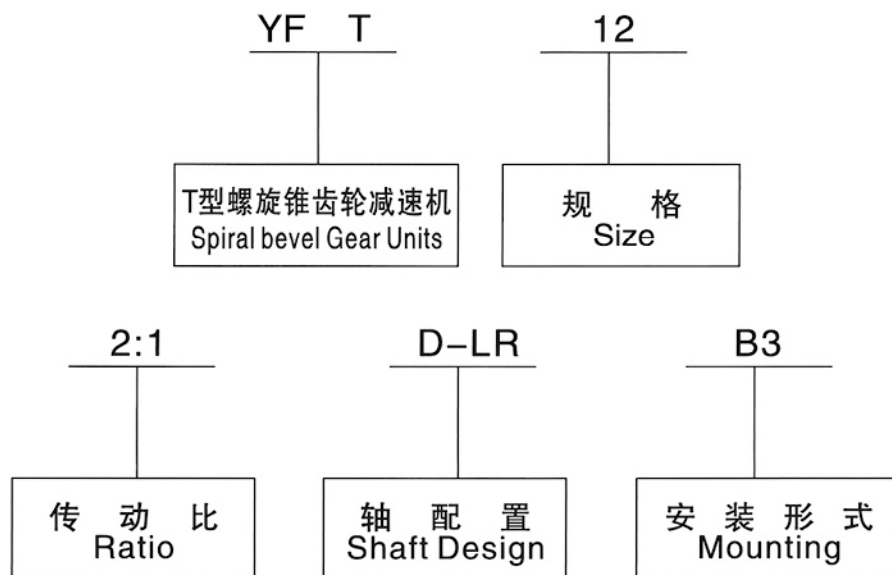

减速机重量 Gear Unit Weight

规格 Size	T2	T4	T6	T7	T8	T10	T12	T16	T20	T25
重量(kg) Weight	2	10	21	32	49	78	124	188	297	488

YFT系列选型举例 YFTseries selection sample YFT系列被驱动设备系数 f. YFTseries service factorf.

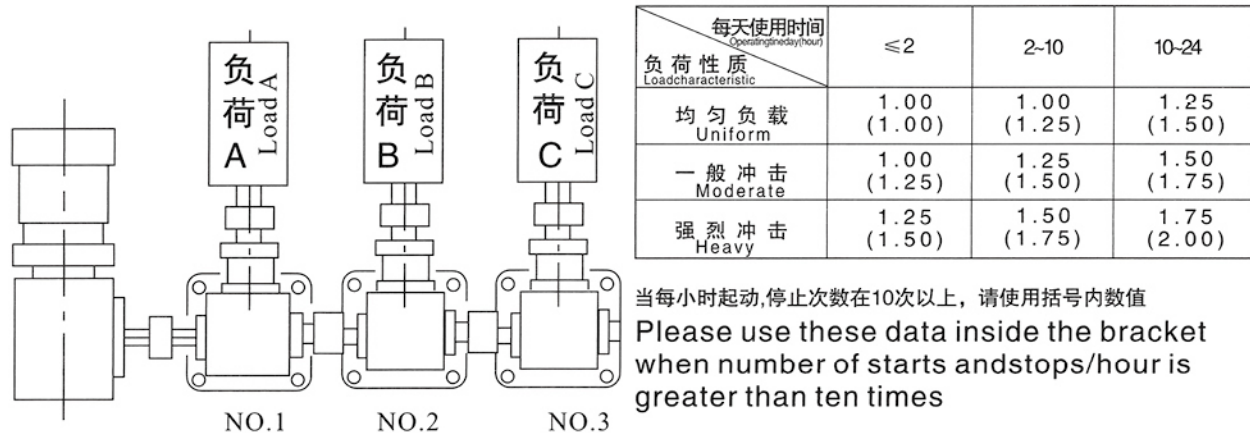

例:3台负载全部为196N.m,一般冲冲击,每天连续工作8小时,即使用系数f1=1.25,斜齿轮

输入轴转速以300r/min,速比全部为1:1.

根据公式: $T_2 = \frac{P_1 \times 9550}{n_1} \times i \times y$

每台齿轮箱本身所需的负载TN2≥T2×f1=196×1.25=245N.m

※1号齿轮箱 因1号齿轮箱本身的负载为245N.m,而2号、3号齿轮箱需通过1号齿轮箱体传递扭矩。所以1号齿轮箱应承担的负载为:

$245N.m + 245N.m + 245N.m = 735N.m$, 依据传动能力表, 应选T12.

※2号齿轮箱 除本身的负载245N.m, 还需传递3号齿轮箱的扭矩。所发总负载应为

$245N.m + 245N.m = 490N.m$, 依据传动能力表, 应选T10.

※3号齿轮箱 由于仅一个负载C进行运转, 即所需负载在245N.m以上即可, 依据传动能力表可选T8.

注意事项:

- 1.本速比不为1:1时,请确定或告知输入轴:选横轴输入为减速,选纵轴输入为增速,安装方位和尺寸确定了以后,就不能更改两轴的位置。
- 2.多台连动输出校对换向箱的承载能力。

Torque loaded on each gearbox is 196Nm, uniform shock, duration of operation is 8 hour per day, service factor f1=1.25, input speed is 300rpm. ratio is 1:1.

Calculate according to formula: $T_2 = \frac{P_1 \times 9550}{n_1} \times i \times y$

Required torque of each gearbox TN2≥T2×f1=196×1.25=245N.m

No.1 gearbox No.1 gearbox carry torque 245Nm, but No.2 and No.3 gearbox need transfer torque through No.1, Consequently No.1 gearbox should carry torque.735Nm(245Nm+245Nm+245Nm). select T12 according to transmission capacity table.

No.2 gearbox No.3 gearbox still transfers torque of No.3 gearbox besides torque of 245NM, so the total torque is 490 Nm(245Nm+245Nm).select T10 according to transmission capacity table.

No.3 gearbox Required torque is more than 245Nm because of only load C according to transmission capacity table.

Notes:

- 1.If ratio is not 1:1, if input speed on single-extendable shaft, output speed will be reduced; if input speed on double-extendable shaft, output speed will be reduced. When mounting position and dimension are determined, the position of shafts can not be changed.
2. Several T boxes are linked, please verify the load capacity of these boxes.

轴配置及轴旋转方向的关系：
The relationship between shaft arrangement
and direction of shaft rotation:

安装形式：
Installation pattern

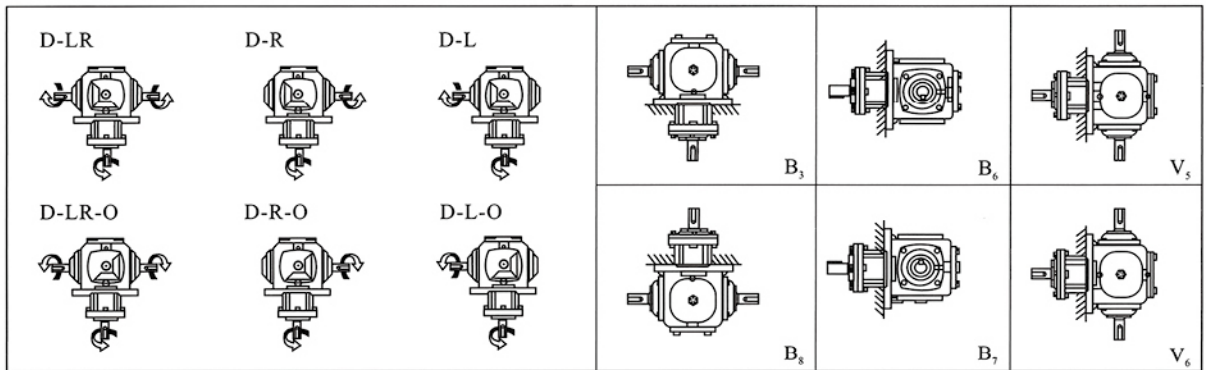
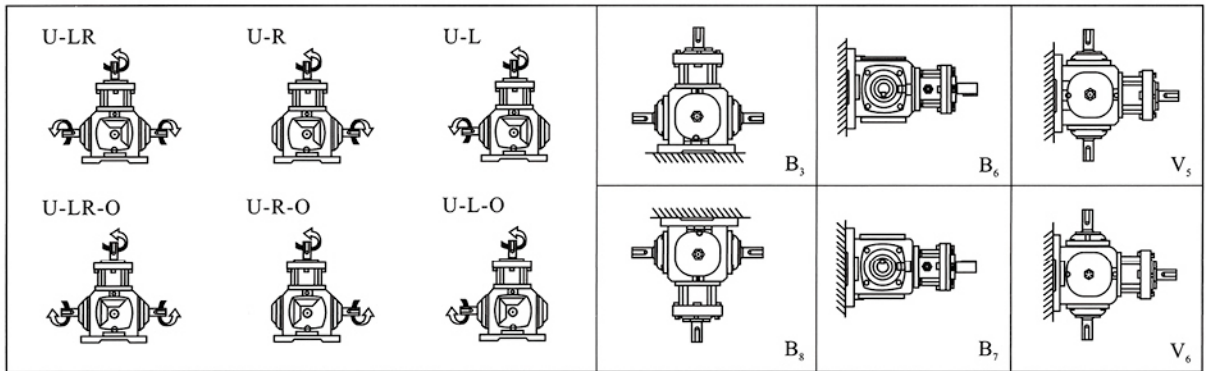
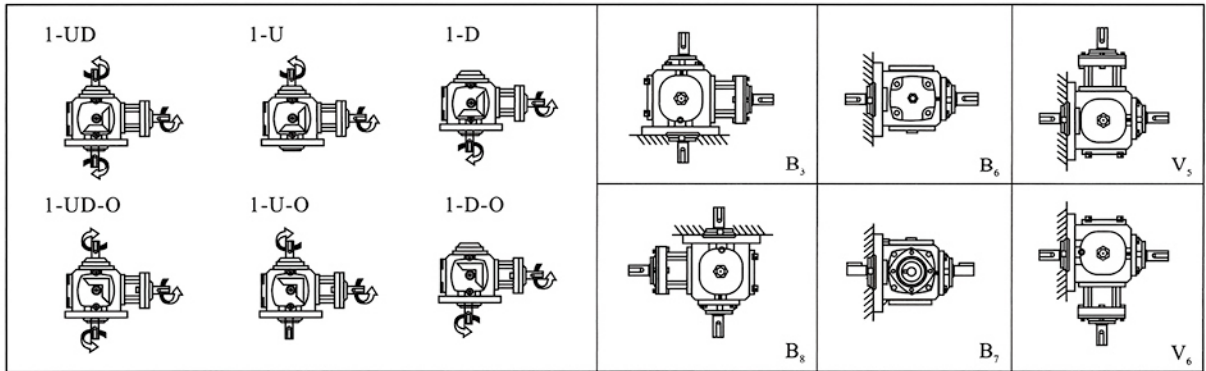
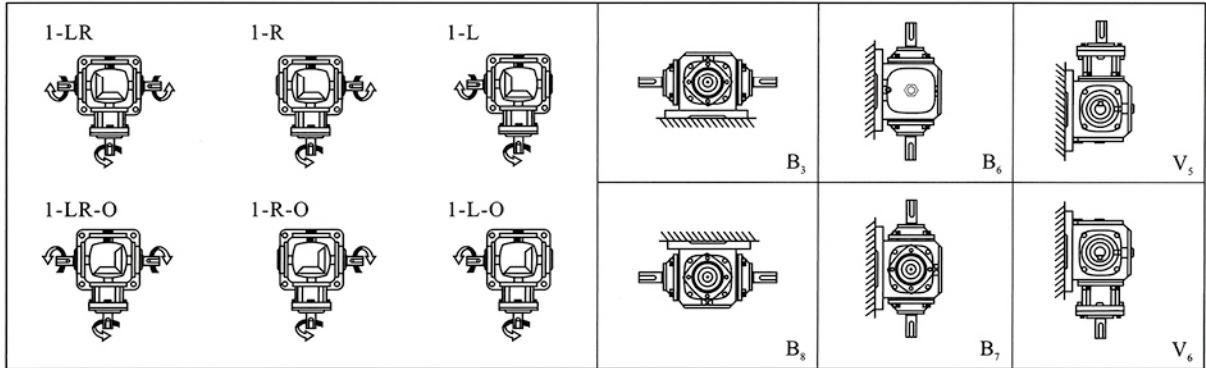

轴配置及轴旋转方向的关系：
The relationship between shaft arrangement and direction of shaft rotation:

安装形式：
Installation pattern

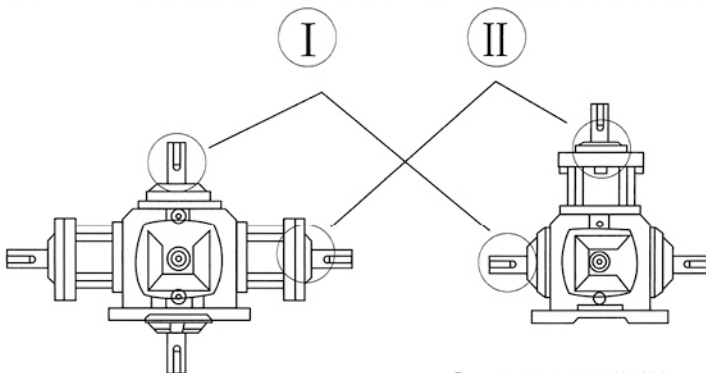
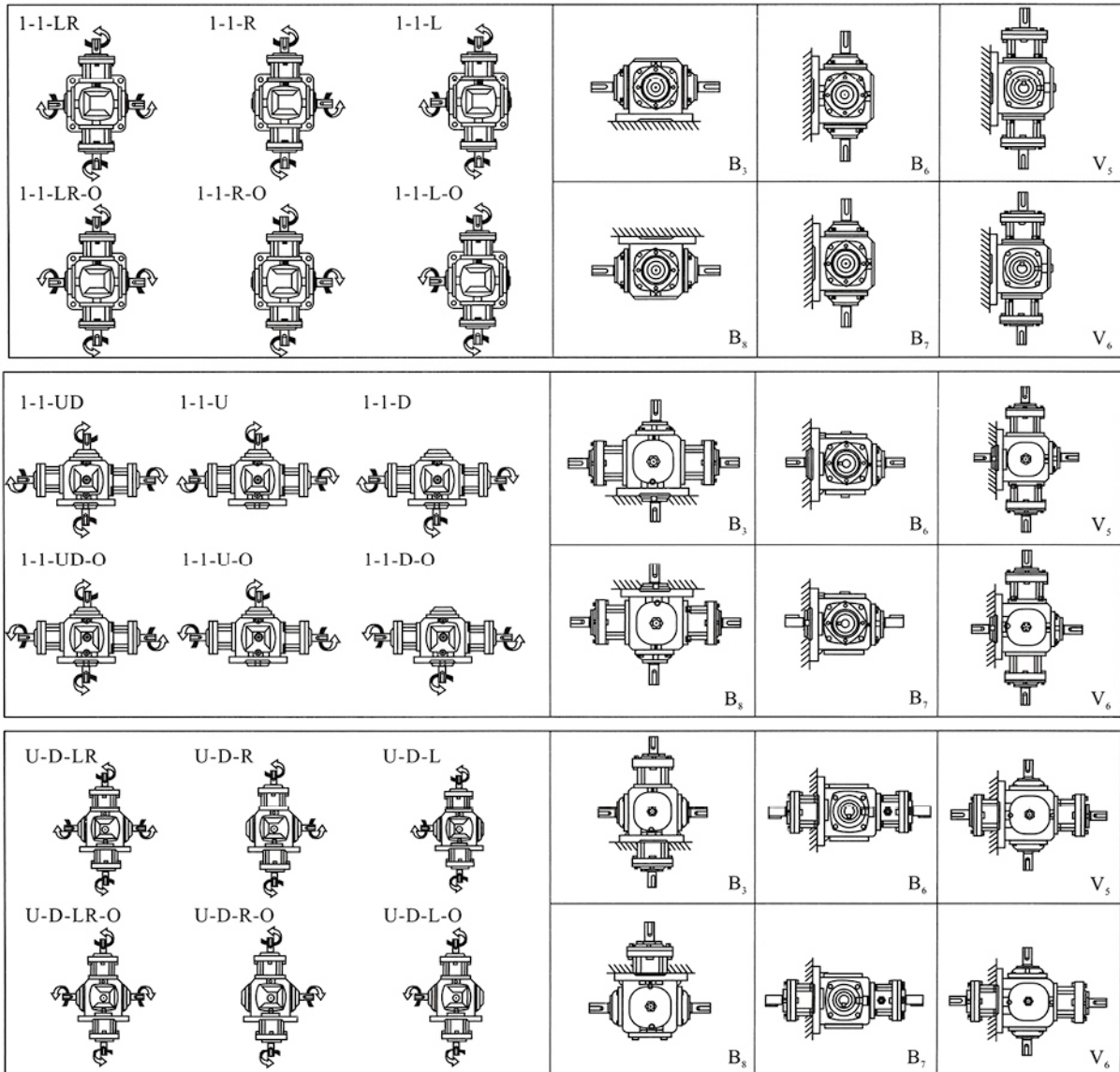

当Ⅱ型轴输入Ⅰ型轴输出时为减速
当Ⅰ型轴输入Ⅱ型轴输出时为增速

Output speed' II be reduced when the shaft
Ⅱ input and the shaft Ⅰ output
Output speed' II be increased when the shaft
Ⅰ input and the shaft Ⅱ output

T 系列传动能力表：
T performance value table:

i	n1 r/min	T2		T4		T6		T7		T8	
		MN2 (N.m)	PN1 (kW)	MN2 (N.m)	PN1 (kW)	MN2 (N.m)	PN1 (kW)	MN2 (N.m)	PN1 (kW)	MN2 (N.m)	PN1 (kW)
1:1	1450	11.6	1.79	31.9	4.94	96.0	14.9	142	22.0	294	45.6
	1150	11.7	1.43	34.1	4.19	103	12.7	150	18.4	305	37.5
	870	12.1	1.12	37.2	3.46	113	10.5	164	15.2	312	29.0
	580	12.1	0.747	39.5	2.45	119	7.35	184	11.4	319	19.8
	400	12.3	0.524	40.2	1.72	122	5.20	195	8.34	326	14.0
	300	12.3	0.396	40.5	1.30	123	3.93	198	6.35	331	10.6
	200	12.4	0.226	41.2	0.880	124	2.66	201	4.30	338	7.23
	100	12.7	0.136	41.9	0.448	127	1.36	206	2.20	346	3.70
10	13.0	0.014	43.0	0.046	132	0.141	214	0.228	361	0.386	
1.5:1	1450					117	12.1	145	15.0	185	19.1
	1150					122	9.96	147	12.0	188	15.4
	870					123	7.66	150	9.30	191	11.8
	580					126	5.23	153	6.32	197	8.14
	400					128	3.66	155	4.41	200	5.70
	300					129	2.77	157	3.35	203	4.34
	200					131	1.87	160	2.28	204	2.91
	100					134	0.957	163	1.16	210	1.49
10					139	0.099	169	0.12	218	0.155	
2:1	1450	12.1	0.94	42.8	3.32	102	7.90	137	10.6	180	14.0
	1150	12	0.74	43.4	2.67	104	6.39	139	8.55	183	11.3
	870	12	0.56	43.8	2.04	105	4.88	141	6.56	187	8.70
	580	11.9	0.37	44.4	1.38	108	3.34	144	4.47	191	5.92
	400	12.2	0.26	45.1	0.96	109	2.33	146	3.12	194	4.15
	300	11.9	0.19	45.5	0.73	110	1.76	148	2.37	196	3.14
	200	12.2	0.13	46.1	0.49	111	1.18	149	1.59	198	2.12
	100	11.2	0.06	46.6	0.25	114	0.608	152	0.812	202	1.08
10	28.1	0.015	48.5	0.026	116	0.062	157	0.084	209	0.112	
2.5:1	1450					96.2	5.97	113	6.99	184	11.4
	1150					97.2	4.78	115	5.64	185	9.11
	870					99.0	3.68	116	4.30	188	7.00
	580					100.0	2.48	118	2.92	192	4.76
	400					100.9	1.73	120	2.05	195	3.34
	300					102.9	1.32	121	1.55	197	2.53
	200					103.9	0.888	123	1.05	200	1.71
	100					104.9	0.448	123	0.528	203	0.867
10					107.8	0.046	126	0.054	208	0.089	
3:1	1450					93.6	4.84	105	5.42	159	8.20
	1150					94.8	3.88	106	4.34	160	6.55
	870					95.9	2.97	108	3.34	163	5.04
	580					97.6	2.02	109	2.25	166	3.42
	400					99.0	1.41	111	1.58	168	2.39
	300					100	1.07	111	1.18	169	1.80
	200					100	0.712	113	0.803	171	1.22
	100					102	0.363	115	0.409	173	0.618
10					104	0.037	118	0.042	179	0.064	
4:1	1450					80.6	3.12	93.4	3.62	124	4.80
	1150					81.5	2.50	94.3	2.90	125	3.83
	870					82.4	1.92	95.9	2.23	127	2.95
	580					84.1	1.30	96.9	1.50	129	2.00
	400					85.1	0.91	98.7	1.05	131	1.40
	300					86.1	0.69	98.3	0.79	131	1.05
	200					86.0	0.46	101	0.54	134	0.71
	100					87.7	0.23	101	0.27	135	0.36
10					89.3	0.02	101	0.03	140	0.04	
5:1	1450					52.0	1.61	57.4	1.78	68.7	2.13
	1150					52.5	1.29	58.0	1.43	69.2	1.70
	870					53.2	0.99	59.0	1.10	70.4	1.31
	580					54.2	0.67	59.6	0.74	71.7	0.89
	400					54.9	0.47	60.7	0.52	72.6	0.62
	300					55.5	0.36	60.4	0.39	72.9	0.47
	200					55.4	0.24	61.7	0.26	74.1	0.32
	100					56.5	0.12	62.9	0.13	75.1	0.16
10					57.6	0.01	64.5	0.01	77.8	0.02	

1、横轴转速未达到10r/min时，请使用10r/min的数据。 1、Horizontal speed $n > 10r/min$ $n = 10r/min$
 注：☒样本中选型表格内涂阴影线的型号产品，定货时请与厂方咨询。
 Please inquire with manufacturer when you will purchase types with shadow backgrounds in catalog.☒

T 系列传动能力表:
T performance value table:

i	n1 r/min	T10		T12		T16		T20		T25	
		MN2 (N.m)	PN1 (kW)	MN2 (N.m)	PN1 (kW)	MN2 (N.m)	PN1 (kW)	MN2 (N.m)	PN1 (kW)	MN2 (N.m)	PN1 (kW)
1:1	1450	421	65.3	619	96.0	1019	163				
	1150	453	55.7	665	81.1	1098	139	1842	234		
	870	479	44.6	726	67.5	1186	114	2009	193	3489	335
	580	493	30.6	802	49.7	1343	85.9	2274	115	3940	252
	400	504	21.5	821	35.1	1499	66.1	2538	112	4410	195
	300	513	16.4	835	26.8	1637	54.1	2744	90.8	4792	159
	200	521	11.1	852	18.2	1784	39.3	3126	69.0	5390	119
	100	535	5.72	875	9.36	1842	20.3	3205	35.3	5439	60.0
	10	561	0.599	919	0.983	1940	2.14	3205	3.53	5713	6.30
1.5:1	1450	374	38.7	564	58.3						
	1150	380	31.2	601	49.2						
	870	389	24.1	656	40.7						
	580	396	16.4	699	28.9						
	400	406	11.6	711	20.3						
	300	411	8.78	724	15.5						
	200	417	5.95	736	10.5						
	100	426	3.04	754	5.37						
	10	443	0.316	785	0.56						
2:1	1450	305	23.6	516	40.0	921	73.7	1878	126		
	1150	309	19.0	516	31.7	938	59.5	1607	102	3146	189
	870	315	14.6	516	24.0	958	46.0	1646	79.0	3224	155
	580	322	10.0	524	16.3	980	31.3	1695	54.2	3332	107
	400	328	7.02	538	11.5	1000	22.0	1725	38.0	3420	75.4
	300	332	5.33	543	8.71	1009	16.7	1754	29.0	3479	57.5
	200	338	3.61	551	5.89	1029	11.3	1784	19.7	3557	39.2
	100	344	1.84	563	3.01	1058	5.84	1833	10.1	3646	20.1
	10	357	0.191	586	0.313	1098	0.605	1921	1.06	3822	2.11
2.5:1	1450	293	18.2	507	31.4						
	1150	298	14.7	514	25.3						
	870	302	11.2	523	19.5						
	580	310	7.68	535	13.3						
	400	315	5.38	545	9.32						
	300	317	4.06	552	7.08						
	200	321	2.75	560	4.79						
	100	326	1.40	568	2.43						
	10	336	0.144	588	0.251						
3:1	1450	270	14.0	458	23.6	904	48.2	1529	82.3	2935	158
	1150	275	11.3	464	19.0	920	38.9	1561	66.6	3045	130
	870	279	8.66	469	14.6	940	30.1	1598	51.6	3135	101
	580	285	5.89	480	9.92	960	20.4	1644	35.4	3246	69.9
	400	288	4.11	490	6.98	978	14.4	1672	24.8	3317	49.3
	300	291	3.11	495	5.29	990	10.9	1701	18.9	3372	37.6
	200	294	2.10	501	3.57	1005	7.38	1733	12.9	3449	25.6
	100	300	1.07	510	1.82	1038	3.82	1777	6.60	3537	13.1
	10	308	0.110	527	0.188	1076	0.40	1865	0.69	3713	1.4
4:1	1450	241	9.35	434	16.8	850	34.3	1452	58.7	2798	113
	1150	246	7.54	441	13.5	865	27.7	1483	47.5	2892	92.6
	870	249	5.78	448	10.4	884	21.4	1518	36.8	2978	72.2
	580	254	3.93	456	7.07	902	14.6	1562	25.2	3084	49.8
	400	257	2.74	465	4.97	919	10.2	1588	17.7	3151	35.1
	300	259	2.08	470	3.77	930	7.8	1616	13.5	3204	26.8
	200	262	1.40	476	2.54	944	5.3	1646	9.17	3276	18.2
	100	267	0.71	485	1.30	976	2.7	1688	4.70	3360	9.36
	10	275	0.07	501	0.13	1011	0.3	1772	0.49	3527	0.98
5:1	1450	136	4.21	296	9.18	814	26.3	1391	44.9	2631	85.0
	1150	138	3.39	301	7.39	828	21.2	1420	36.4	2771	71.0
	870	140	2.60	305	5.68	847	16.4	1454	28.2	2853	55.3
	580	143	1.77	311	3.86	864	11.2	1496	19.3	2954	38.2
	400	144	1.23	318	2.72	881	7.85	1521	13.6	3018	26.9
	300	146	0.93	321	2.06	891	5.96	1548	10.3	3069	20.5
	200	148	0.63	325	1.39	905	4.03	1577	7.03	3138	14.0
	100	150	0.32	331	0.71	935	2.08	1617	3.60	3218	7.17
	10	155	0.03	342	0.07	969	0.22	1697	0.38	3378	0.75

1、横轴转速未达到10r/min时,请使用10r/min的数据。 1、Horizontal speed n>10r/min n=10r/min
注:图中本中选型表格内涂阴影线的型号产品,定货时请与厂方咨询。
Please inquire with manufacturer when you will purchase types with shadow backgrounds in catalog.

T 系列径向载荷表(Fr):
T performance value table(Fr):

i N	n1 (r/min)	T2		T4		T6		T7		T8		T10		T12		T16		T20		T25	
		横轴	纵轴	横轴	纵轴	横轴	纵轴	横轴	纵轴	横轴	纵轴	横轴	纵轴	横轴	纵轴	横轴	纵轴	横轴	纵轴	横轴	纵轴
		Horizontal	Vertical	Horizontal	Vertical	Horizontal	Vertical	Horizontal	Vertical	Horizontal	Vertical	Horizontal	Vertical	Horizontal	Vertical	Horizontal	Vertical	Horizontal	Vertical	Horizontal	Vertical
1 : 1	1450	265	216	833	951	1911	2450	2450	3136	3234	3381	4165	4508	5096	5586	10633	10976				
	1150	323	235	882	1029	2058	2597	2744	3234	3479	3626	4459	4851	5488	6076	11368	11760	15386	15608		
	870	402	255	960	1127	2205	2842	2989	3381	3773	3969	4851	5292	5880	6566	12446	12740	16660	17150	24794	25480
	580	549	314	1078	1323	2499	3185	3381	3822	4263	4459	5488	5880	6713	7301	14014	14504	18816	19404	28028	28910
	400	637	353	1372	1715	3185	3528	4018	4900	4851	5978	6272	7056	7742	8134	15680	16170	21070	21756	31360	32340
	300	696	392	1519	1960	3430	3528	4410	5537	5243	6958	6713	7987	8232	9065	17150	17640	23422	24108	34300	35280
	200	784	441	1911	1960	3430	3528	5096	6272	7889	8820	8575	9604	9261	10290	19600	19894	25970	26754	38612	39788
	100	980	588	1911	1960	3430	3528	5096	6272	8428	8820	9996	11760	11368	12593	22540	22540	28420	32928	39200	49000
	10	980	588	1911	1960	3430	3528	5096	6272	8428	8820	9996	11760	11858	14504	22540	22540	28420	33320	39200	49000
1.5 : 1	1450			1078	1960	2548	2842	3430	5390	4361	7987	5194	9212	5978	10486	5978	12152	7693	14602		
	1150			1078	1960	3038	3087	4067	5978	5096	8820	6174	10486	7252	12152	6419	13083	8771	17934	12985	24647
	870			1078	1960	3430	3332	4753	6076	6076	8820	7448	11760	8869	14504	6958	14210	9506	19453	13573	29400
	580			1078	1960	3430	3528	5096	6174	7644	8820	9555	11760	11466	14504	7840	16072	10780	22001	15680	33222
	400			1078	1960	3430	3528	5096	6272	8428	8820	9996	11760	11858	14504	8820	17934	12005	24598	17542	37142
	300			1078	1960	3430	3528	5096	6272	8428	8820	9996	11760	11858	14504	9604	19600	13132	27342	19159	40474
	200			1078	1960	3430	3528	5096	6272	8428	8820	9996	11760	11858	14504	10829	22148	14798	30282	21658	45766
	100			1078	1960	3430	3528	5096	6272	8428	8820	9996	11760	11858	14504	13328	22540	18228	33320	26656	49000
	10			1078	1960	3430	3528	5096	6272	8428	8820	9996	11760	11858	14504	22540	22540	28420	33320	39200	49000

备注：各规格最低的输出转速按以上最大Fr值。
The lowest output rotation rate of each specification according to above biggest Fr data

YFT2

1-LR、1-R、1-L、1-LR-O、1-R-O、1-L-O

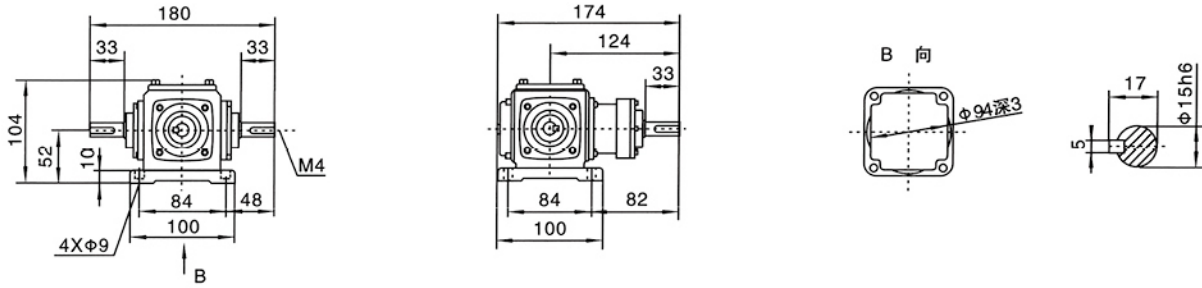

1-UD、1-U、1-D、1-UD-O、1-U-O、1-D-O

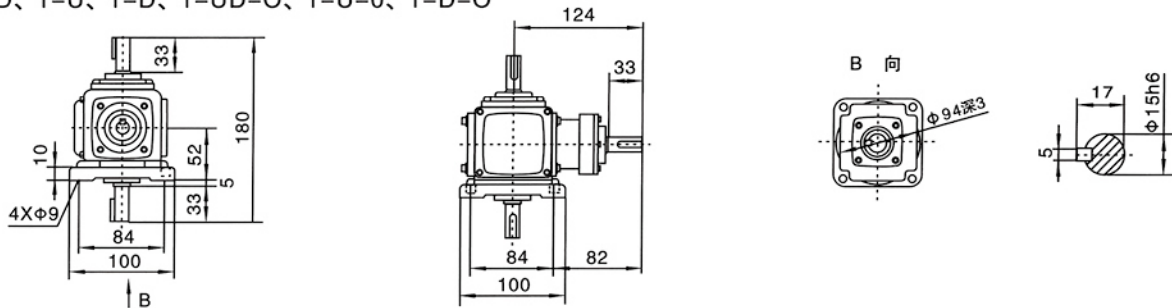

U-LR、U-R、U-L、U-LR-O、U-R-O、U-L-O

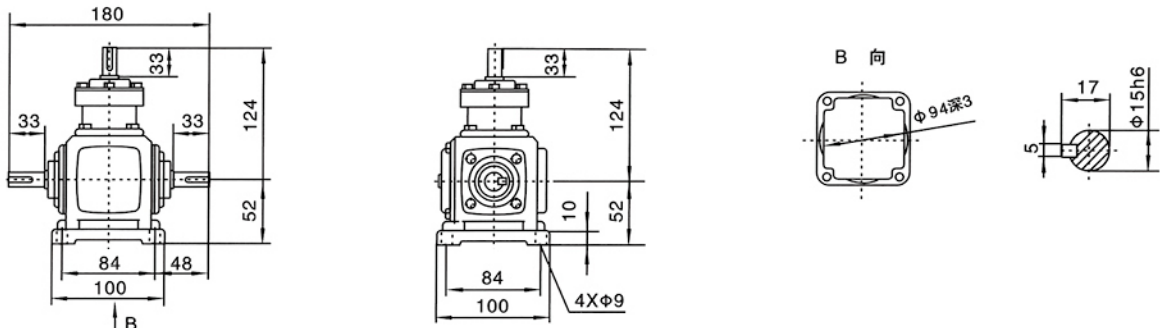

D-LR、D-R、D-L、D-LR-O、D-R-O、D-L-O

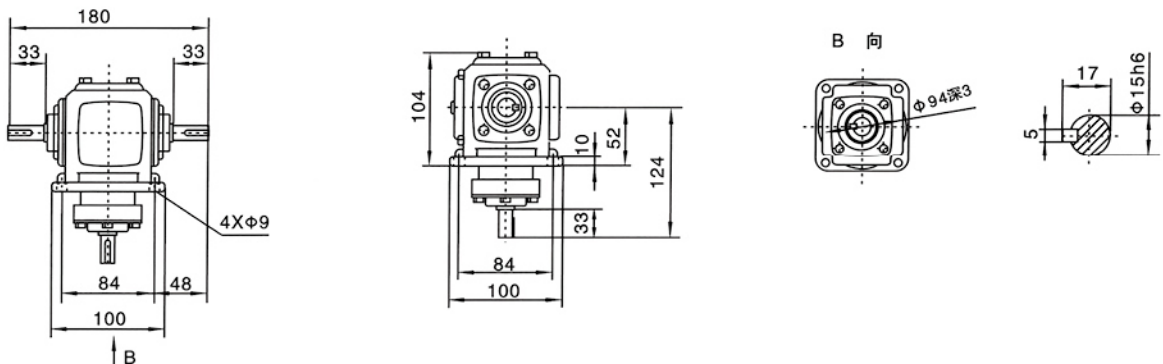

1-1-LR、1-1-R、1-1-L
1-1-LR-O、1-1-R-O、1-1-L-O

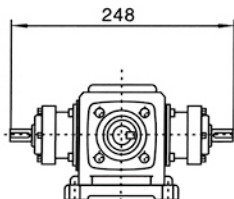

1-1-UD、1-1-U、1-1-D
1-1-UD-O、1-1-U-O、1-1-D-O

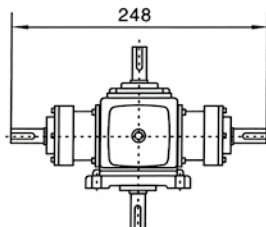

U-D-LR、U-D-R、U-D-L
U-D-LR-O、U-D-R-O、U-D-L-O

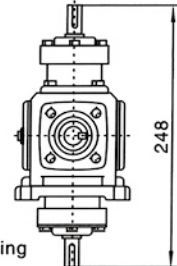

注：YFT壳体为通用件，安装尺寸均可相互参照。

Note: The housings of YFT are common parts. The mounting dimensions may consult each other.

YFT4

1-LR、1-R、1-L、1-LR-O、1-R-O、1-L-O

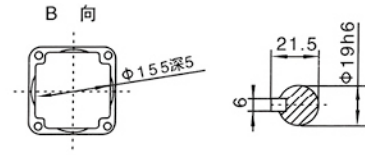
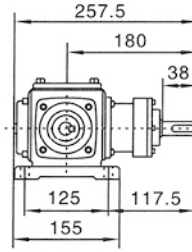
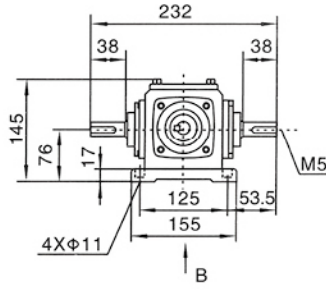

1-UD、1-U、1-D、1-UD-O、1-U-O、1-D-O

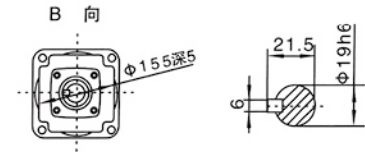
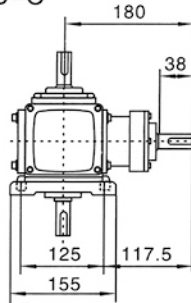
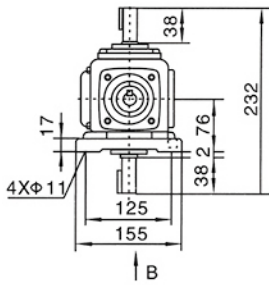

U-LR、U-R、U-L、U-LR-O、U-R-O、U-L-O

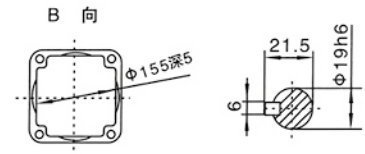
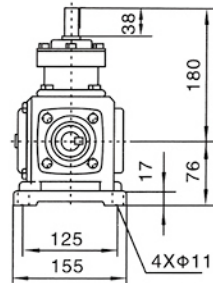
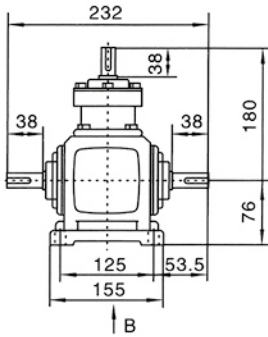

D-LR、D-R、D-L、D-LR-O、D-R-O、D-L-O

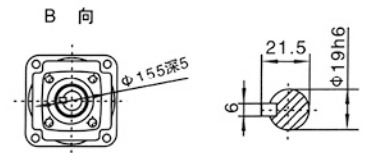
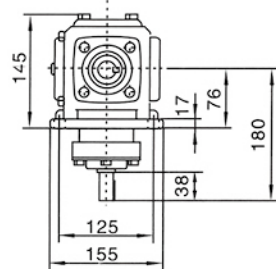
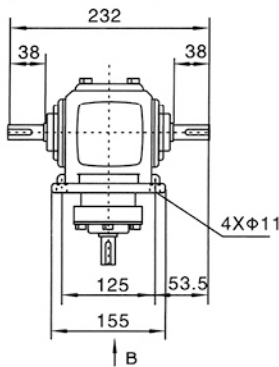

1-1-LR、1-1-R、1-1-L
1-1-LR-O、1-1-R-O、1-1-L-O

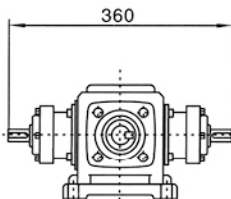

1-1-UD、1-1-U、1-1-D
1-1-UD-O、1-1-U-O、1-1-D-O

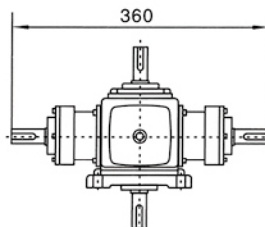

U-D-LR、U-D-R、U-D-L
U-D-LR-O、U-D-R-O、U-D-L-O

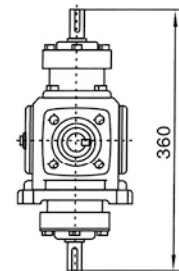

注：YFT壳体为通用件，安装尺寸均可相互参照。

Note: The housings of YFT are common parts. The mounting dimensions may consult each other.

YFT6

1-LR, 1-R, 1-L, 1-LR-O, 1-R-O, 1-L-O

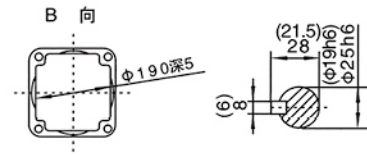
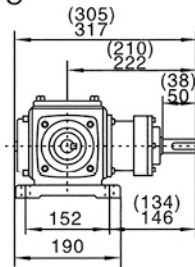
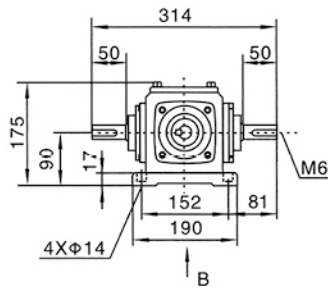

1-UD, 1-U, 1-D, 1-UD-O, 1-U-O, 1-D-O

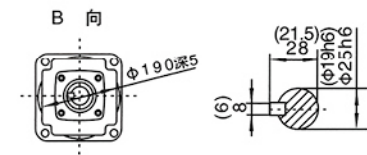
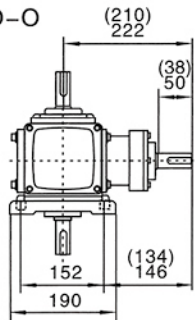
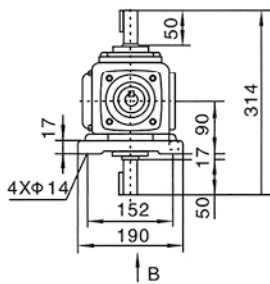

U-LR, U-R, U-L, U-LR-O, U-R-O, U-L-O

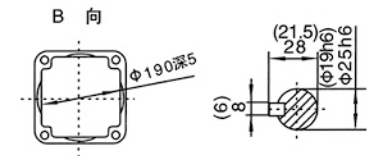
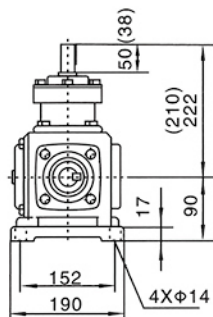
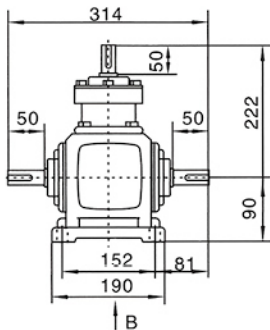

D-LR, D-R, D-L, D-LR-O, D-R-O, D-L-O

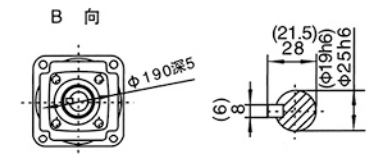
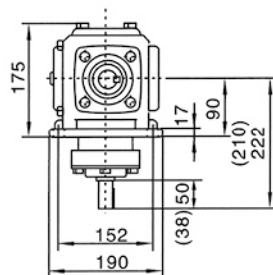
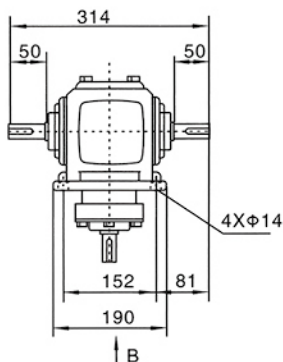

1-1-LR, 1-1-R, 1-1-L
1-1-LR-O, 1-1-R-O, 1-1-L-O

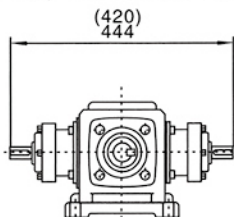

1-1-UD, 1-1-U, 1-1-D
1-1-UD-O, 1-1-U-O, 1-1-D-O

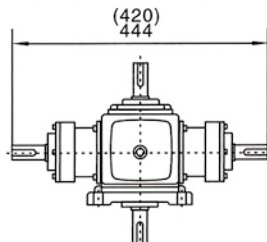

U-D-LR, U-D-R, U-D-L
U-D-LR-O, U-D-R-O, U-D-L-O

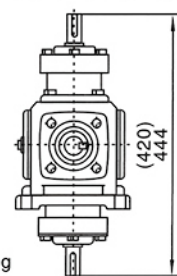

注: YFT壳体为通用件, 安装尺寸均可相互参照。
当4: 1; 5: 1横轴为括号内表示, 纵轴尺寸不变

Note: The housing of YFT are common parts. The mounting dimensions may consult each other.
When ratio is 4:1, 5:1, cross-shaft size marked in parenthesis, dimension of vertical shaft is changeless.

YFT7

1-LR、1-R、1-L、1-LR-O、1-R-O、1-L-O

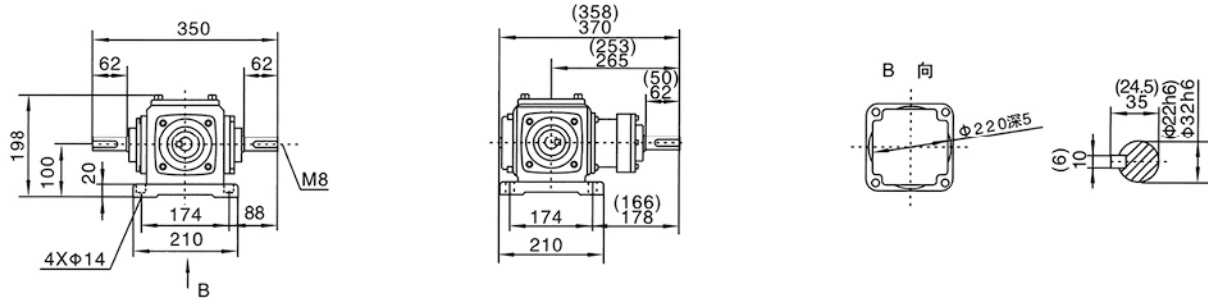

1-UD、1-U、1-D、1-UD-O、1-U-O、1-D-O

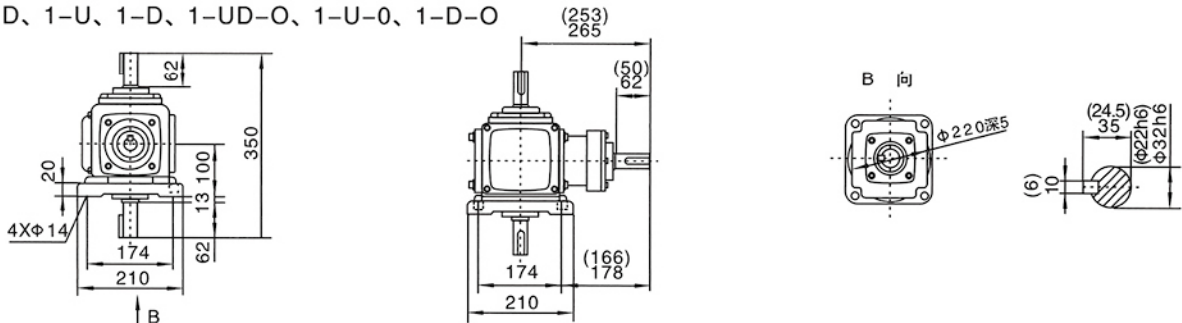

U-LR、U-R、U-L、U-LR-O、U-R-O、U-L-O

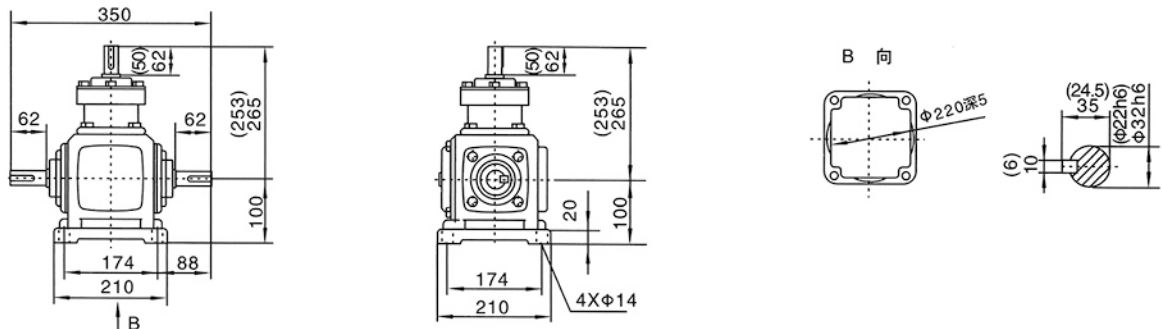

D-LR、D-R、D-L、D-LR-O、D-R-O、D-L-O

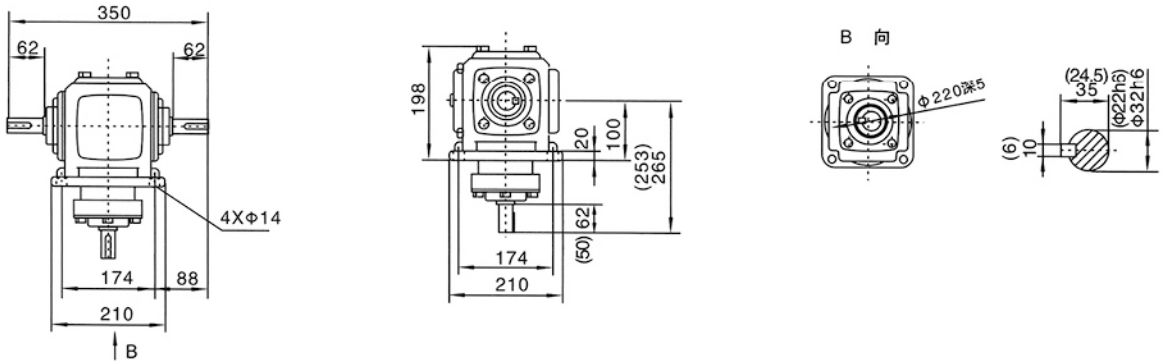

1-1-LR、1-1-R、1-1-L
1-1-LR-O、1-1-R-O、1-1-L-O

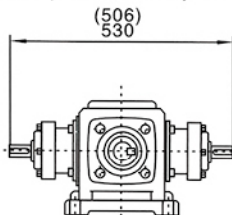

1-1-UD、1-1-U、1-1-D
1-1-UD-O、1-1-U-O、1-1-D-O

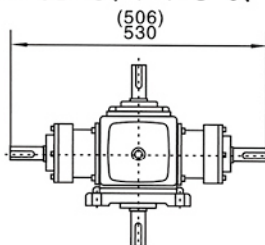

U-D-LR、U-D-R、U-D-L
U-D-LR-O、U-D-R-O、U-D-L-O

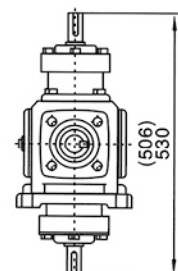

注：YFT壳体为通用件,安装尺寸均可相互参照。
当4: 1; 5: 1横轴为括号内表示,纵轴尺寸不变

Note: The housing of YFT are common parts. The mounting dimensions may consult each other.
When ratio is 4:1, 5:1, cross-shaft size marked in parenthesis, dimension of vertical shaft is changeless.

YFT8

1-LR、1-R、1-L、1-LR-O、1-R-O、1-L-O

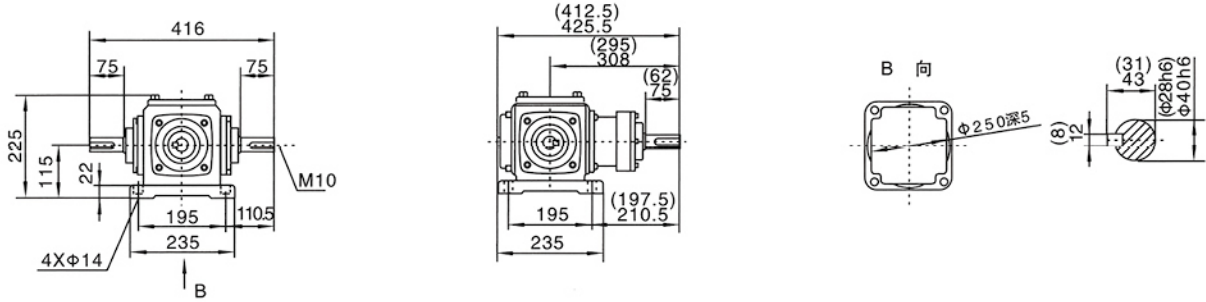

1-UD、1-U、1-D、1-UD-O、1-U-O、1-D-O

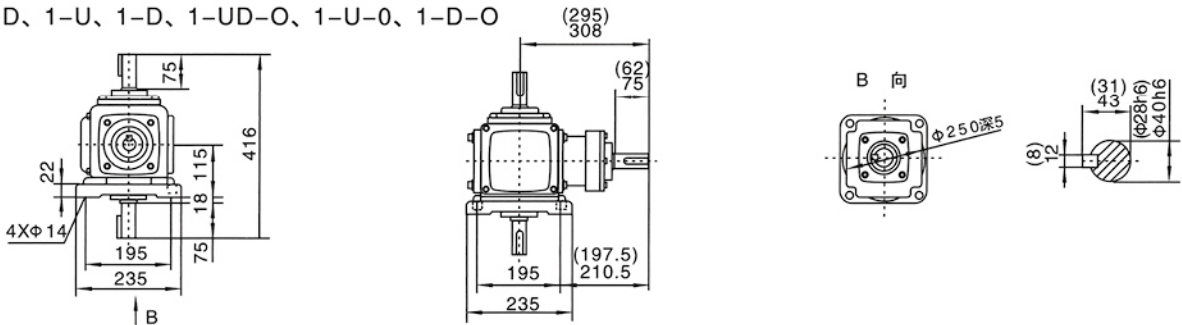

U-LR、U-R、U-L、U-LR-O、U-R-O、U-L-O

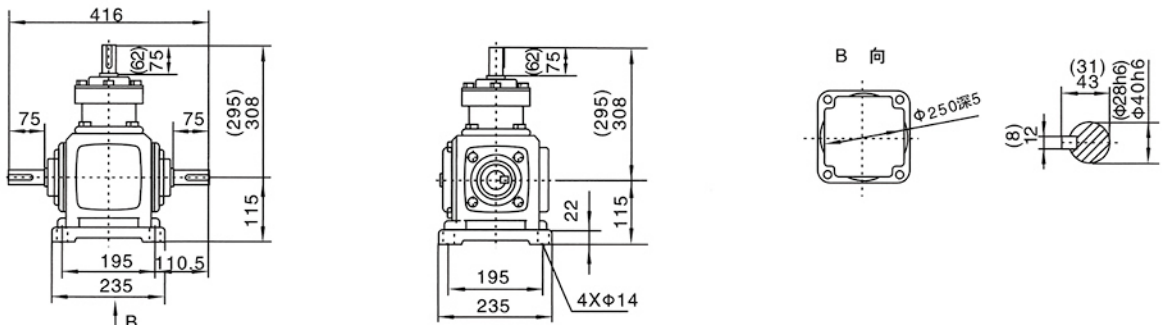

D-LR、D-R、D-L、D-LR-O、D-R-O、D-L-O

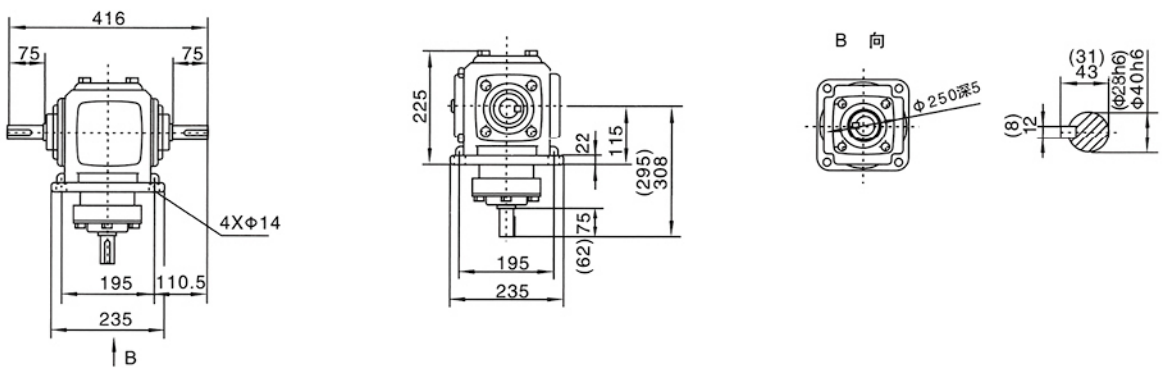

1-1-LR、1-1-R、1-1-L
1-1-LR-O、1-1-R-O、1-1-L-O

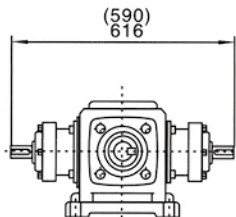

1-1-UD、1-1-U、1-1-D
1-1-UD-O、1-1-U-O、1-1-D-O

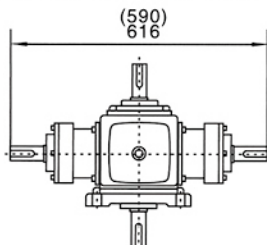

U-D-LR、U-D-R、U-D-L
U-D-LR-O、U-D-R-O、U-D-L-O

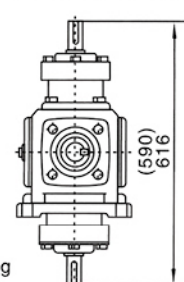

注：YFT壳体为通用件,安装尺寸均可相互参照。
当4: 1; 5: 1横轴为括号内表示,纵轴尺寸不变

Note: The housing of YFT are common parts. The mounting dimensions may consult each other.
When ratio is 4:1, 5:1, cross-shaft size marked in parenthesis, dimension of vertical shaft is changeless.

YFT10

1-LR, 1-R, 1-L, 1-LR-O, 1-R-O, 1-L-O

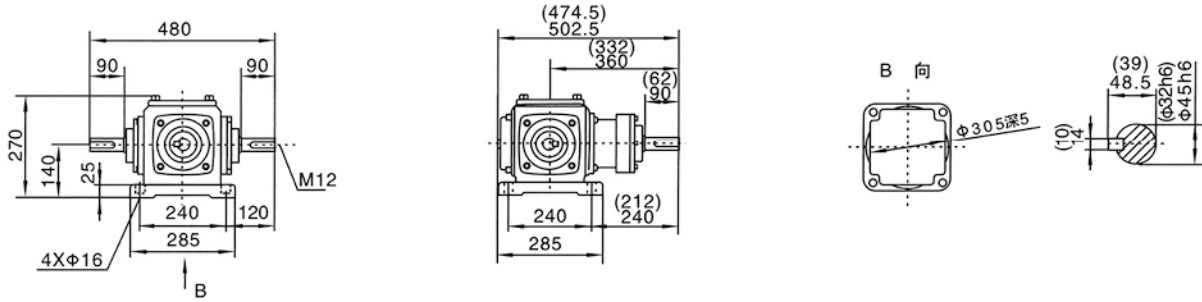

1-UD, 1-U, 1-D, 1-UD-O, 1-U-O, 1-D-O

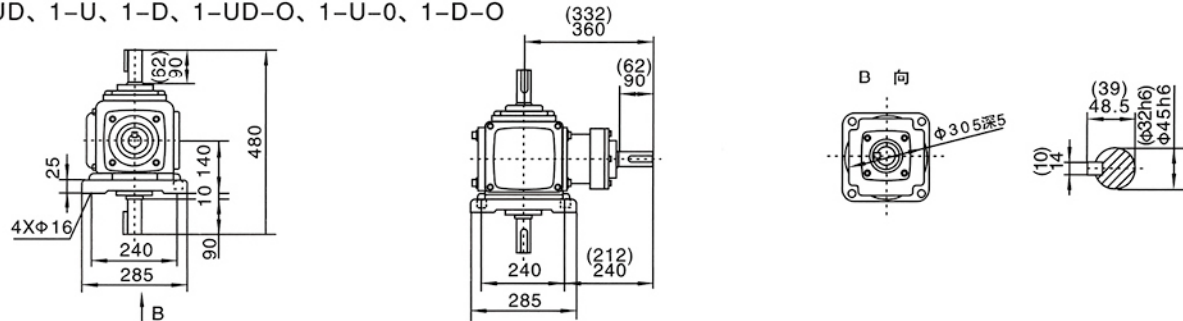

U-LR, U-R, U-L, U-LR-O, U-R-O, U-L-O

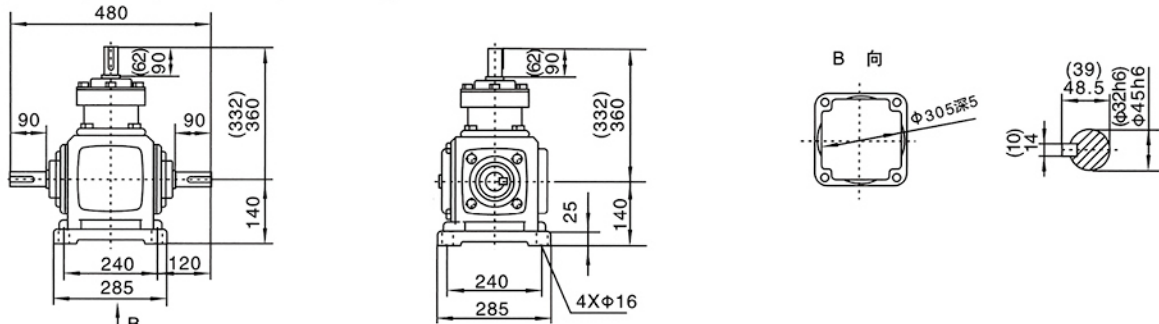

D-LR, D-R, D-L, D-LR-O, D-R-O, D-L-O

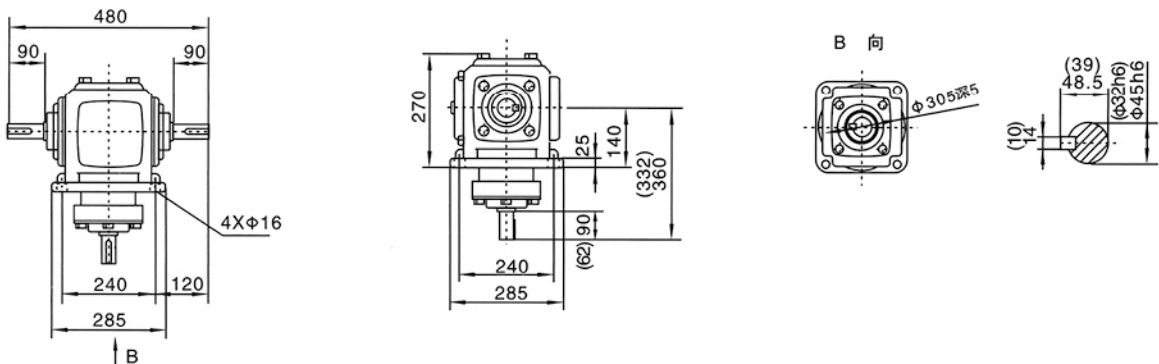

1-1-LR, 1-1-R, 1-1-L
1-1-LR-O, 1-1-R-O, 1-1-L-O

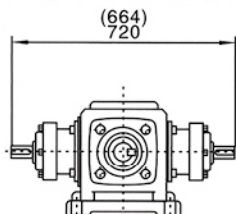

1-1-UD, 1-1-U, 1-1-D
1-1-UD-O, 1-1-U-O, 1-1-D-O

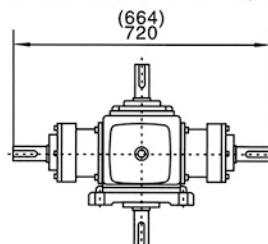

U-D-LR, U-D-R, U-D-L
U-D-LR-O, U-D-R-O, U-D-L-O

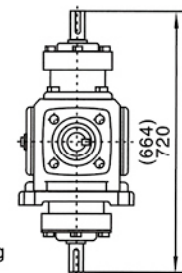

注: YFT壳体为通用件, 安装尺寸均可相互参照。
当4: 1; 5: 1横轴为括号内表示, 纵轴尺寸不变

Note: The housing of YFT are common parts. The mounting dimensions may consult each other.
When ratio is 4:1, 5:1, cross-shaft size marked in parenthesis, dimension of vertical shaft is changeless.

YFT12

1-LR, 1-R, 1-L, 1-LR-O, 1-R-O, 1-L-O

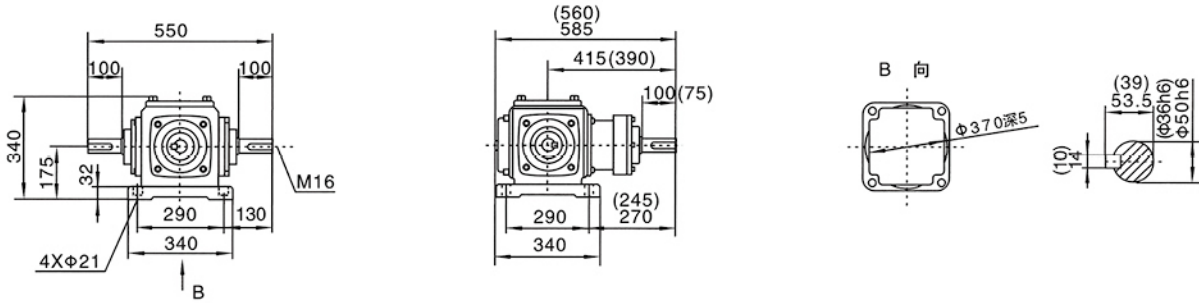

1-UD, 1-U, 1-D, 1-UD-O, 1-U-O, 1-D-O

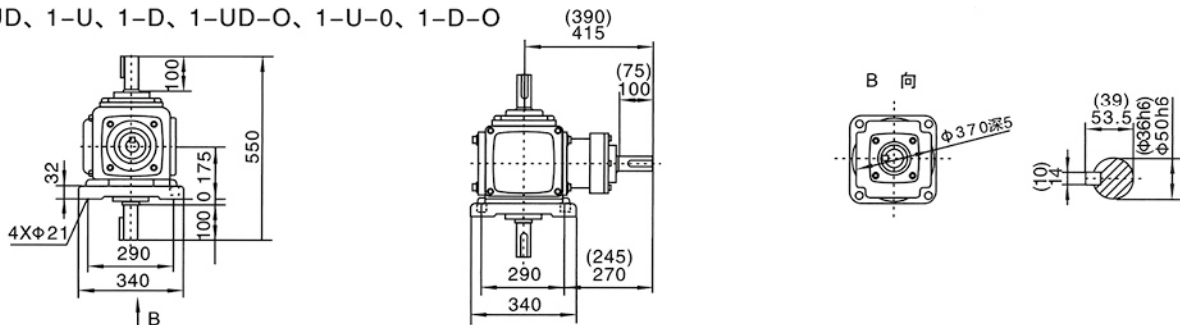

U-LR, U-R, U-L, U-LR-O, U-R-O, U-L-O

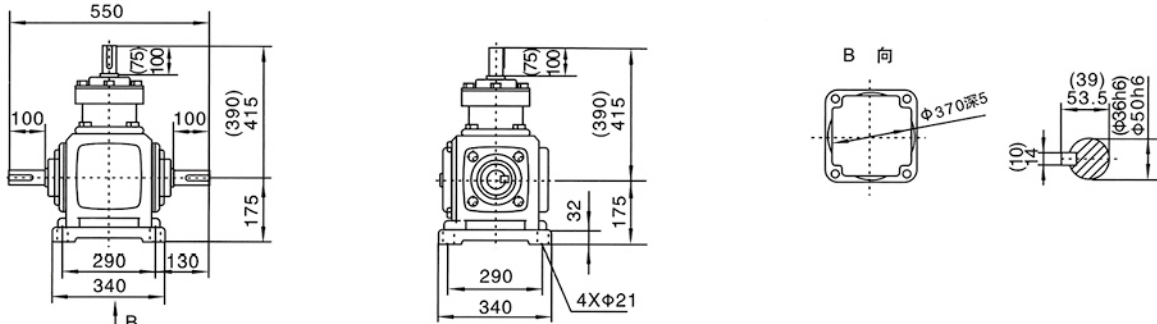

D-LR, D-R, D-L, D-LR-O, D-R-O, D-L-O

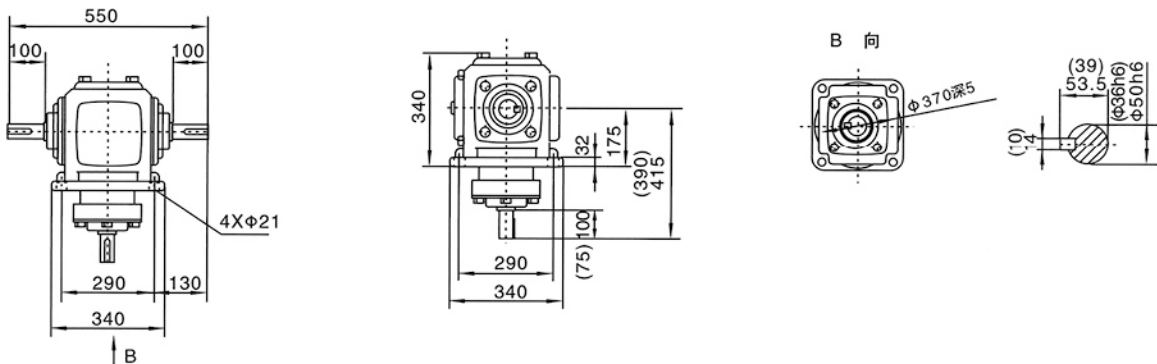

1-1-LR, 1-1-R, 1-1-L
1-1-LR-O, 1-1-R-O, 1-1-L-O

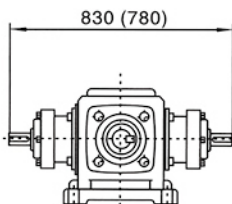

1-1-UD, 1-1-U, 1-1-D
1-1-UD-O, 1-1-U-O, 1-1-D-O

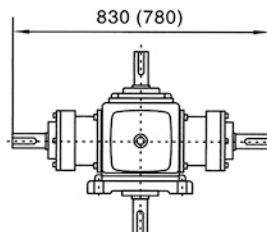

U-D-LR, U-D-R, U-D-L
U-D-LR-O, U-D-R-O, U-D-L-O

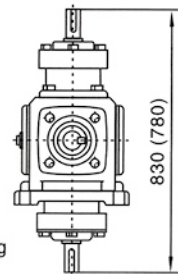

注：YFT壳体为通用件,安装尺寸均可相互参照。
当4: 1; 5: 1横轴为括号内表示,纵轴尺寸不变

Note: The housing of YFT are common parts. The mounting dimensions may consult each other.
When ratio is 4:1, 5:1, cross-shaft size marked in parenthesis, dimension of vertical shaft is changeless.

YFT16

1-LR、1-R、1-L、1-LR-O、1-R-O、1-L-O

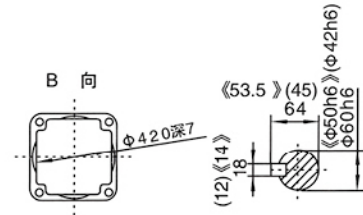
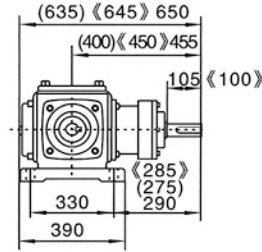
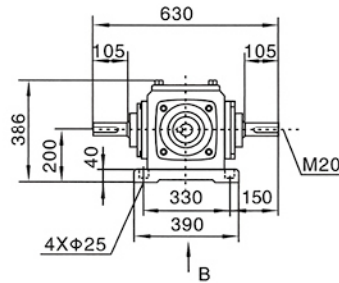

1-UD、1-U、1-D、1-UD-O、1-U-O、1-D-O

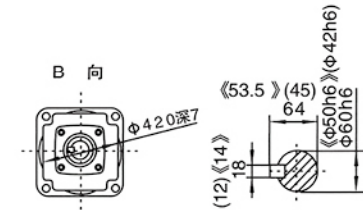
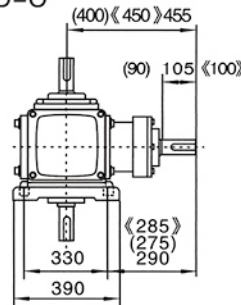
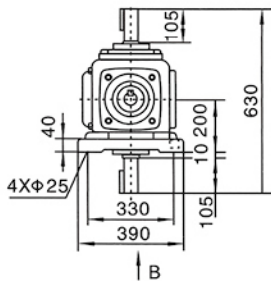

U-LR、U-R、U-L、U-LR-O、U-R-O、U-L-O

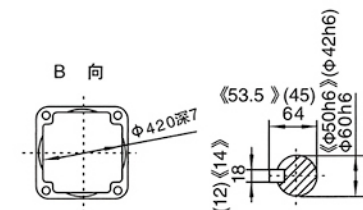
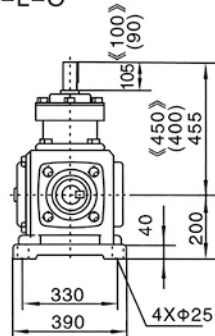
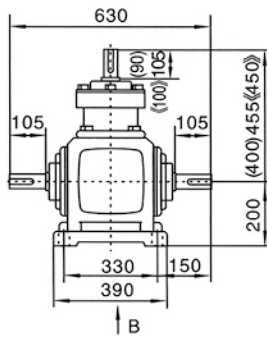

D-LR、D-R、D-L、D-LR-O、D-R-O、D-L-O

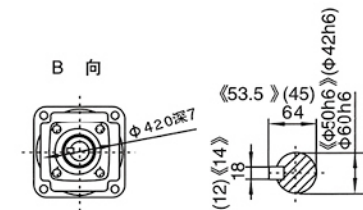
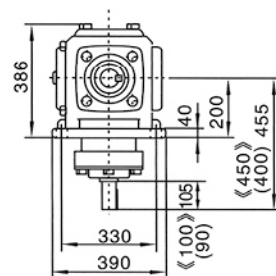
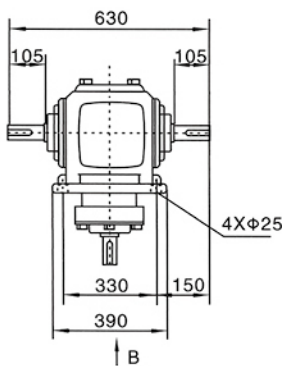

1-1-LR、1-1-R、1-1-L
1-1-LR-O、1-1-R-O、1-1-L-O

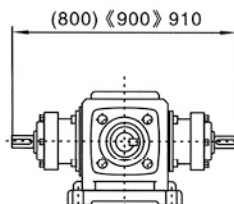

1-1-UD、1-1-U、1-1-D
1-1-UD-O、1-1-U-O、1-1-D-O

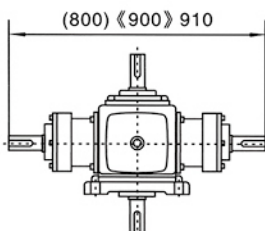

U-D-LR、U-D-R、U-D-L
U-D-LR-O、U-D-R-O、U-D-L-O

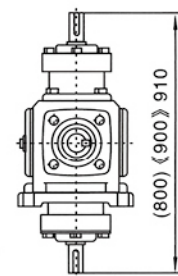

注：YFT壳体为通用件，安装尺寸均可相互参照。
横轴当4:1为《》；5:1用（）表示纵轴尺寸不变

Note: The housing of YFT are common parts. The mounting dimensions may consult each other.
When ratio is 4:1, cross-shaft size marked in double bracket; when ratio is 5:1, cross-shaft size marked in parenthesis, dimension of vertical shaft is changeless.

YFT20

1-LR、1-R、1-L、1-LR-O、1-R-O、1-L-O

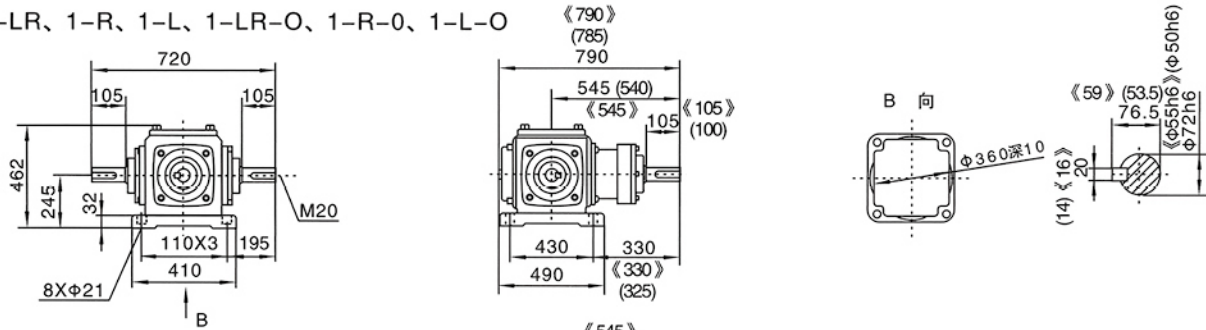

1-UD、1-U、1-D、1-UD-O、1-U-O、1-D-O

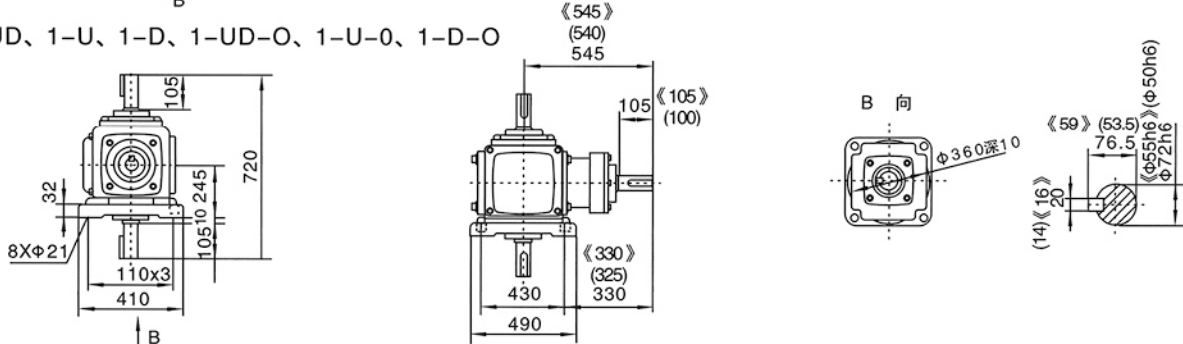

U-LR、U-R、U-L、U-LR-O、U-R-O、U-L-O

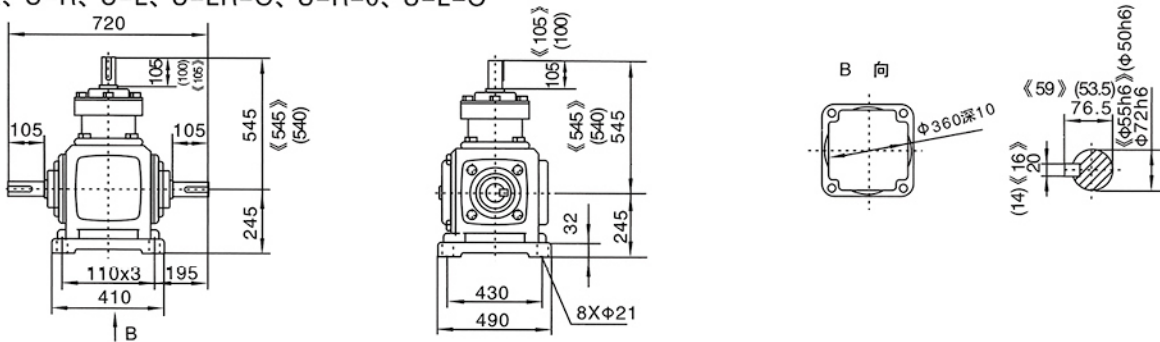

D-LR、D-R、D-L、D-LR-O、D-R-O、D-L-O

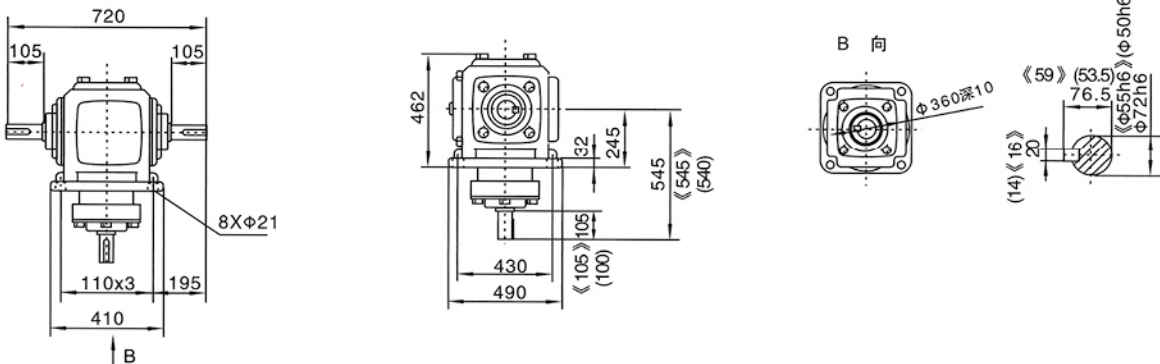

1-1-LR、1-1-R、1-1-L
1-1-LR-O、1-1-R-O、1-1-L-O

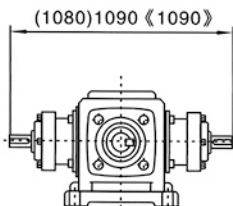

1-1-UD、1-1-U、1-1-D
1-1-UD-O、1-1-U-O、1-1-D-O

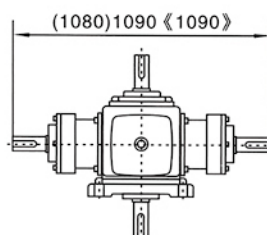

U-D-LR、U-D-R、U-D-L
U-D-LR-O、U-D-R-O、U-D-L-O

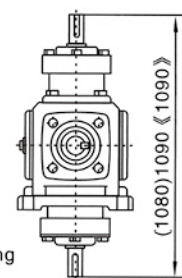

注：YFT壳体为通用件，安装尺寸均可相互参照。
横轴当4:1为《》；5:1用（）表示纵轴尺寸不变

Note: The housing of YFT are common parts. The mounting dimensions may consult each other.
When ratio is 4:1, cross-shaft size marked in double bracket; when ratio is 5:1, cross-shaft size marked in parenthesis, dimension of vertical shaft is changeless.

YFT25

1-LR, 1-R, 1-L, 1-LR-O, 1-R-O, 1-L-O

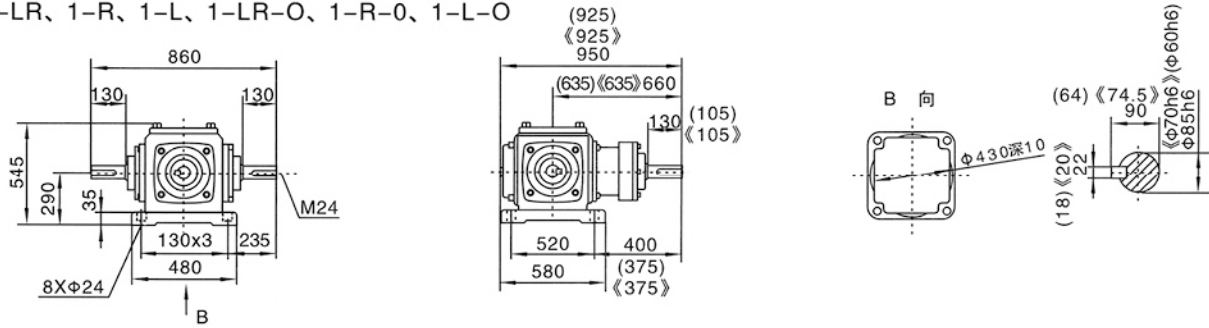

1-UD, 1-U, 1-D, 1-UD-O, 1-U-O, 1-D-O

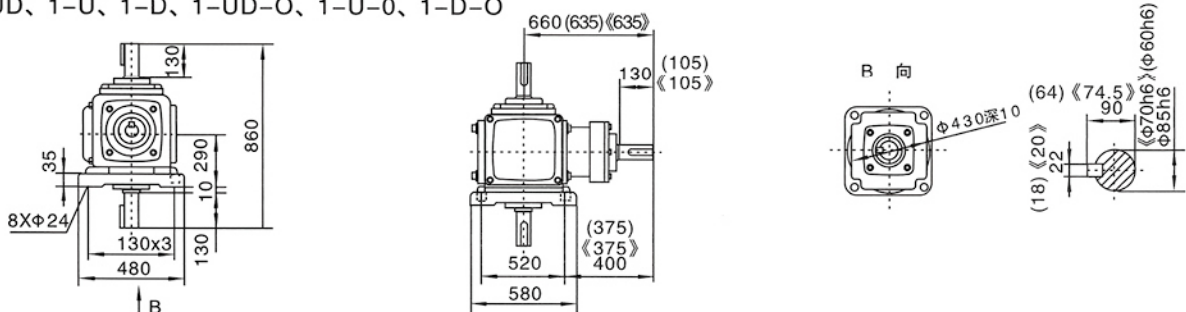

U-LR, U-R, U-L, U-LR-O, U-R-O, U-L-O

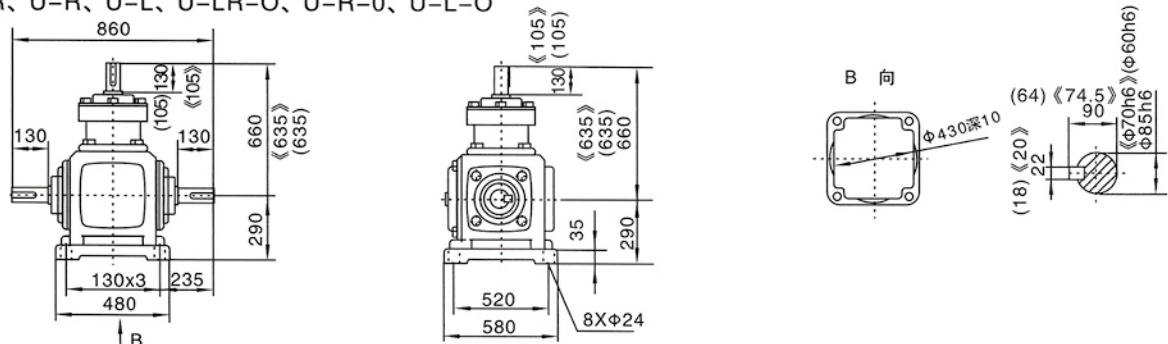

D-LR, D-R, D-L, D-LR-O, D-R-O, D-L-O

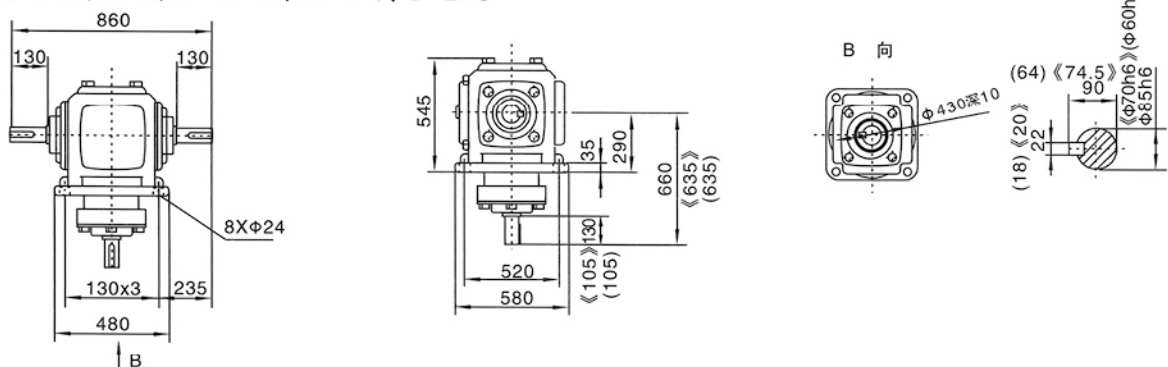

1-1-LR, 1-1-R, 1-1-L
1-1-LR-O, 1-1-R-O, 1-1-L-O

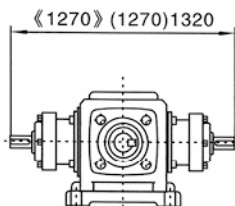

1-1-UD, 1-1-U, 1-1-D
1-1-UD-O, 1-1-U-O, 1-1-D-O

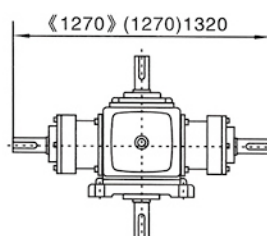

U-D-LR, U-D-R, U-D-L
U-D-LR-O, U-D-R-O, U-D-L-O

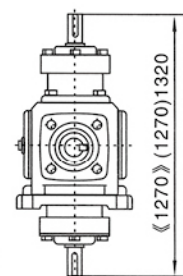

注：YFT壳体为通用件,安装尺寸均可相互参照。
横轴当4:1为《》;5:1用()表示纵轴尺寸不变

Note: The housing of YFT are common parts. The mounting dimensions may consult each other.
When ratio is 4:1, cross-shaft size marked in double bracket; when ratio is 5:1, cross-shaft size marked in parenthesis, dimension of vertical shaft is changeless.